

# Theta 76 Theta 76 HS Multi Format Lab System

The production of small and large print sizes directly from image files is made easy with our fully digital Multi-Lab System Theta 76/76 HS. Please observe closely, because the Theta 76 produces all images continuously on RA4 roll media up to a maximum width of 76.2 cm, thus allowing print sizes from 9 x 13 cm (3.5 x 5 in.) to 76,2 cm x 4 m (30 in. x 13 ft). With this enormous flexibility a multitude of new applications and business opportunities are opening themselves for you. Whether its portrait or wedding photography, whether studio or minilab – there are no jobs that you can not accomplish at optimum quality. Theta prints with a resolution of 254 ppi continuous tone (which corresponds with about 1.200 dpi) and a linear printing speed of up to a max. of 72 cm (28 in.) per minute. This means, that you can from now on reliably produce standard print sizes, panorama prints, each with or without cropping, package prints, print series and so on, either as cut single images or as panels up to 4 m (13 ft.).

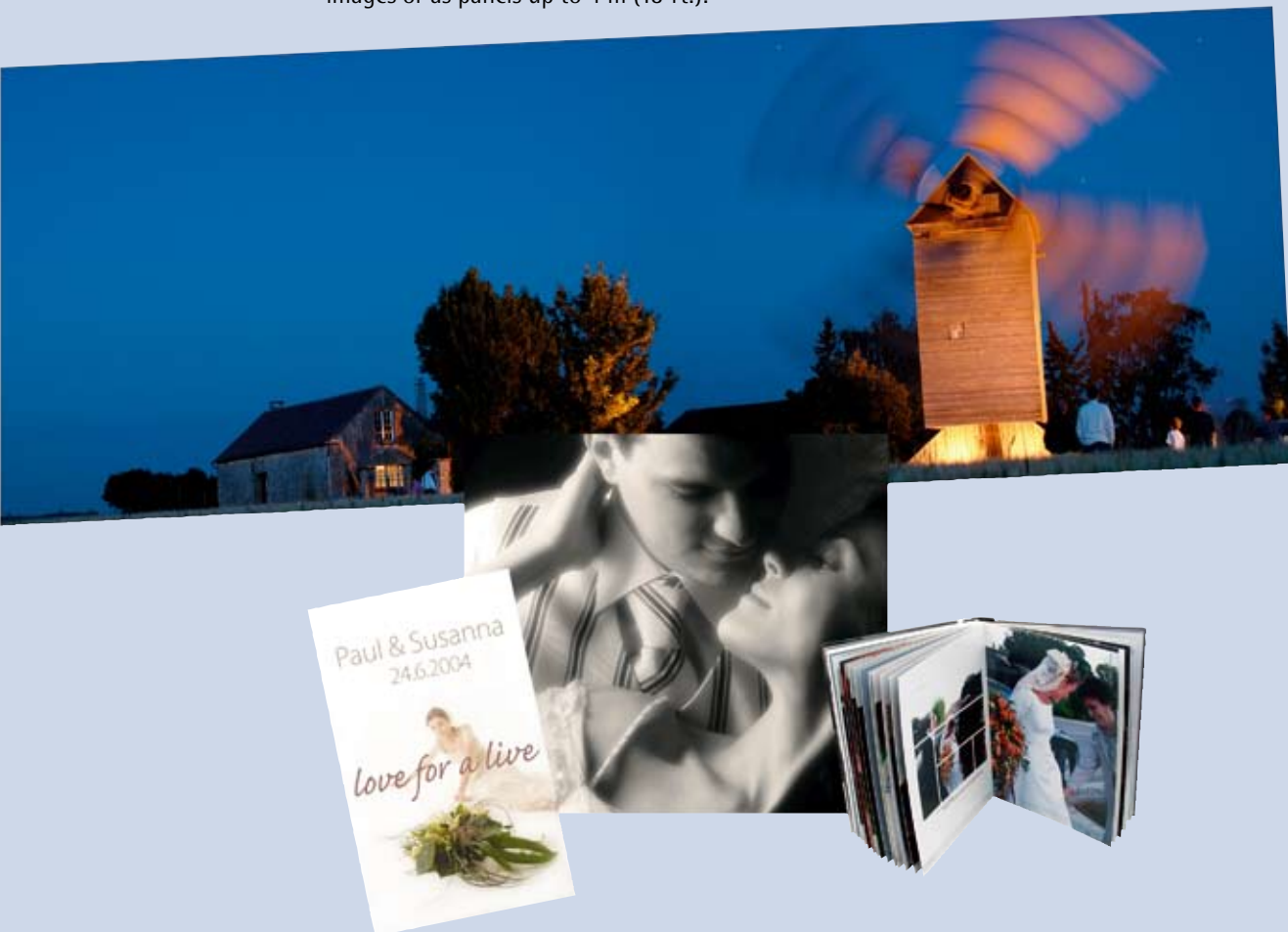

**With many new formats to many new businesses!**

You will produce as flexible as never before! Previously almost impossible print size requests can now be produced easily with Theta 76/76 HS. From standard prints sized 9 x 13 cm (3.5 x 5 in.) to 76 cm (30 in.) all the way up to 4 m (13 ft.) long panorama prints, all poster prints, mix format orders, as well as long, double sided print sizes for trendy "digital albums" - all that becomes normal, daily work for you.

You are working with a production capacity of 370 prints per hour in 20 x 25 cm (8 x 10 in.) format at maximum exposure speed on the largest possible roll width. This corresponds with a capacity of over 18 m<sup>2</sup>/hour (193 sq. ft.). Outstanding in its performance, Theta 76 produces up to 1.120 prints in 10 x 15 cm format per hour, 370 prints in 20 x 25 cm format per hour, 47 prints in 50 x 75 cm format per hour or 24 prints in 76 x 100 cm format per hour.

With Theta 76 HS your production capacity will increase another 50 %, which equals to 27 m<sup>2</sup>, over 2.000 prints 9 x 13 cm (3,5 x 5 in.) or 70 posters 50 x 70 cm (20 x 30 in.)

#### **Convincing image quality**

The 254 PPI resolution "full continuous tone" exposure of Theta 76 generates a perfect image definition from image edge to image edge.

#### **Superior material utilization**

Theta 76 positions images side by side on panels or strips. With its special auto nesting software and multiple print function an optimal material utilization is guaranteed. Even its productivity is increased by the connected, automatic cutting device, which makes sure that images are cut to the correct sizes.



© Javier Cruces

#### **Surprising even on the reverse side**

With Theta you receive the only digital printer, that can print on the back of single cut images and at side-by-side nested images on a wider media roll.

© Patrick Cointepoix





### Profit from the trend.



Digital photo albums become more and more popular as they are a creative and attractive medium to present memories exclusively and individually. It does not matter how different the requested formats are, Theta is well versed in all of them. Offer your clients album sizes they way they desire. With Theta you can produce fast and easy double sided albums pages for weddings, vacations and many other occasions.

### Win new customers with additional services.



Make your customer a desirable offer with attractive indexprints and professional contact sheets. Instead of standard print sizes you create exactly the sizes that your customers want. Here, even the most demanding customer will be pleased!

### Lead in print sizes - it will be worth it!



Panorama images are the show piece of any lab. Theta produces first class panaroma images in any desired length just with the push of a button. Do we have to tell you that your image will also expand in view of service and competence?

## Which Theta is the right one for you?

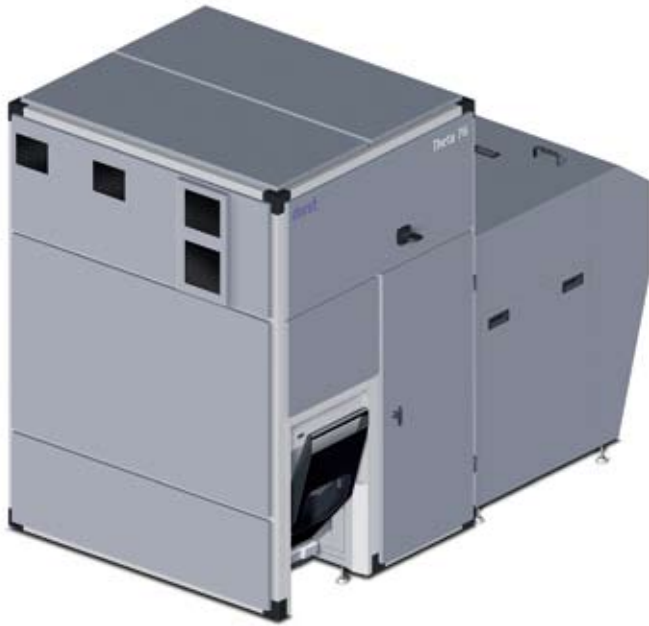

### Theta 76

Here we introduce you to the cost-efficient versions. Equipped with a high speed digital imager, daylight paper cassette, the connected RA4 paper processor and a front end workstation, your daily work is improved and at the highest standard.

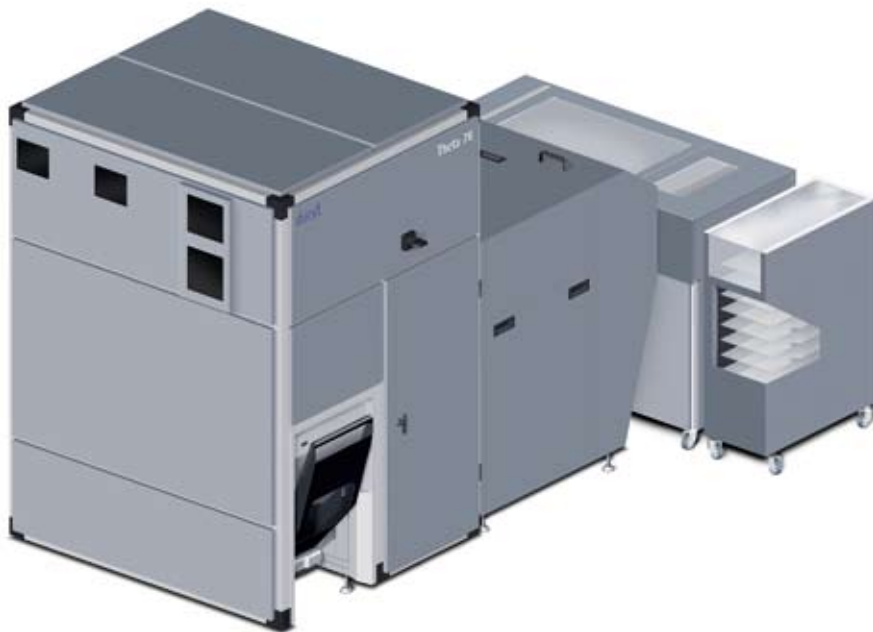

### Theta 76 CS

You can reach the optimum productivity and operating comfort with our complete version, additionally equipped with the connected cutter & sorter station. Your everyday lab day would conceive a significant appreciation with the Theta 76 CS:

- minilab like operation up to the ready cut and completely sorted print order
- shorter run-through time on all mixed format orders
- the high print size flexibility makes poster prints and panorama images up to 4 m length possible
- double sided album pages for weddings and events in any image length. You satisfy your customers wishes at lower cost and superior quality.

At the same time, Theta 76 CS reaches a production capacity of nearly 200 cut prints 20 x 25 cm (8 x 10 in.) per hour, or alternatively, 370 prints 20 x 25 cm (8 x 10 in.) at maximum printing speed on strips of the largest roll width.

### Theta 76 HS

#### Theta 76 CS-HS

Theta 76 is also available as High-Speed version in order to match your high production requirements, reaching 27 m<sup>2</sup>, equal to over 2.000 prints 9 x 13 cm (3.5 x 5 in.) or 70 posters 50 x 70 cm (20 x 30 in.)

## Durst Fiber Optic (DFO) Technology

The DFO technology is the heart of our system. Monochrome LED's (red, green, blue) produce light which is projected as pixels over glass fiber cable and optics line-by-line with 254 ppi printing resolution/256 levels onto photo sensitive material. The DFO technology becomes unique through its media calibration system consisting of densitometer, scanner and the corresponding software whereby the majority of materials are calibrated to an optimum. The DFO technology features an LED light source with an extremely long life time of close to 100.000 hours, thus combining proven Durst image quality at extremely low maintenance costs.

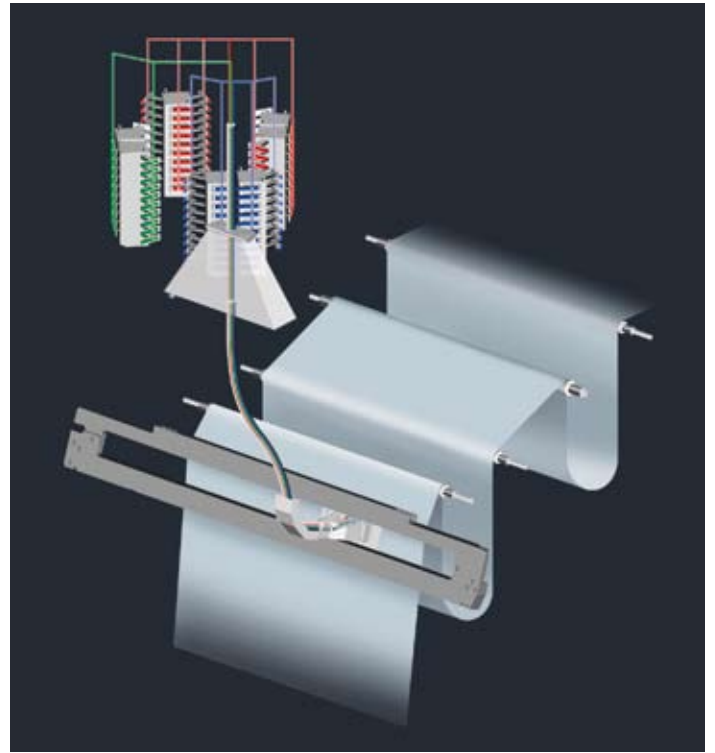

## Digital, automatic workflow

The image data is automatically "retrieved" from the data server. The scaling also occurs automatically – and without further manual intervention, the ICC conversion, printing, processing, cutting and sorting takes place. All this together really leads to a fully automatic, digital workflow.

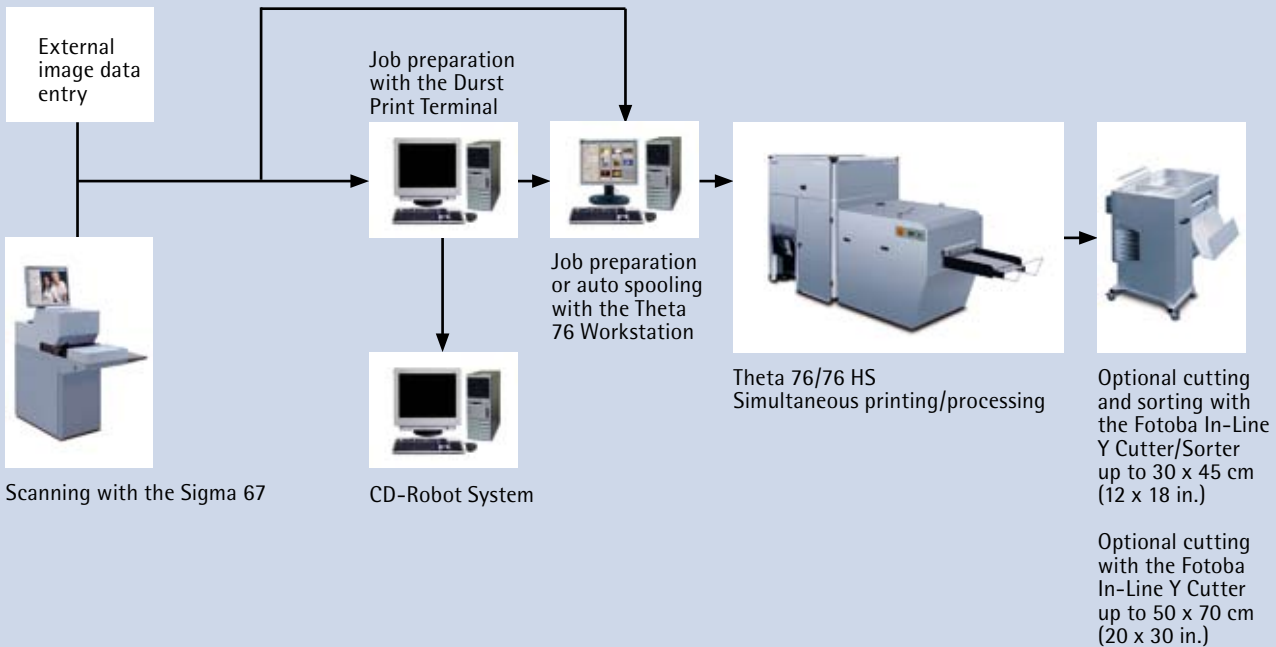

## The "Brain" of your Theta 76 – The software

The special programmed Theta 76 software is the intelligent pre-condition for save and trouble-free processes. The software runs on a high-performance Windows XP Professional Workstation and accomplishes all important work such as:

- Automatic image correction with I2E™-software
- Automatic file scaling
- Automatic file rotation,
- Automatic sharpening
- Color Management
- Auto-Nesting, Multiprints
- Index Prints

Our software works with high speed - and therefore lowers significantly the waiting time of the printer. An important part in the workflow is also the multi tasking, whereby jobs are prepared at simultaneous printing of already prepared jobs.

### Spooling without any breaks

The description "spooling" means the fully automatic and continues loading of files from the server station whereby already spooled jobs are printed simultaneously.

### Direct correction with "soft proofing"

New is also the "Soft proofing" function, allowing a direct correction of single images or multiple images in thumbnail size on the screen. A deciding advantage is the operation safety which results in improved image quality.

### Here we convert colors correct: the color management software

The fully automatic Color-Management Workflow converts TIFF, JPEG, BMP and PPM files with:

- Choice of desired ICC input profile with rendering intents
- automatic recognition of embedded ICC profiles
- Automatic selection of the correct output profiles assigned to the paper channel.

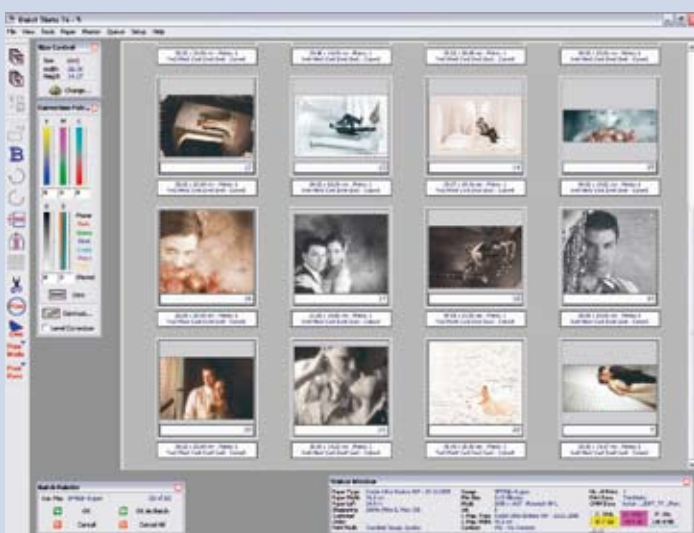
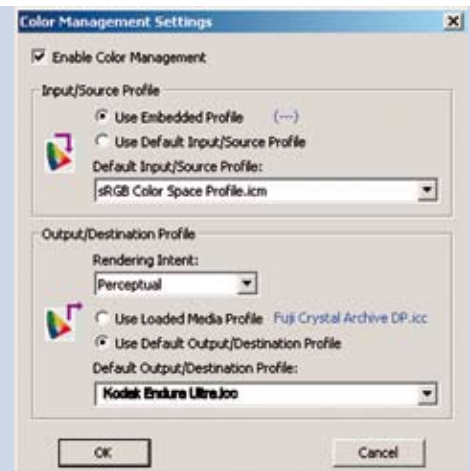
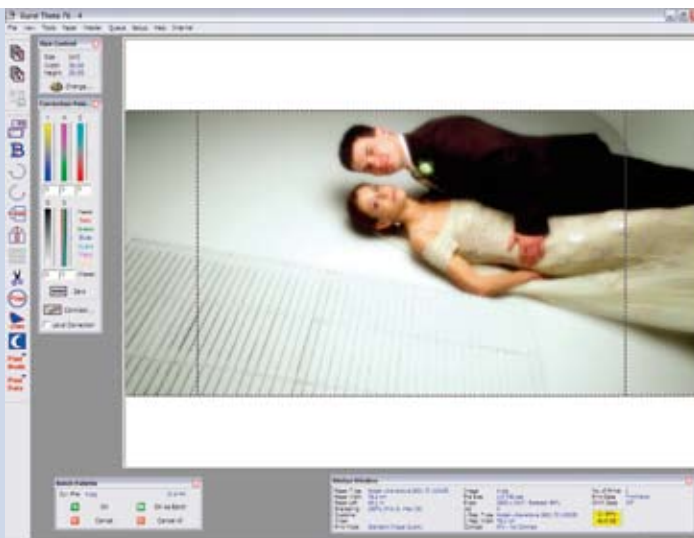

## The paper cassette: functional and practical.

The 100 % light tight and wheel mounted paper cassette can be easily loaded from the front side of the imager. The cassette allows full daylight use and accepts media roll widths from 20.3 cm (8 in.) up to 76.2 cm (30 in.) at a max. length of 175 m (530 ft.). For printing, the paper is transported out of the cassette and in case of a cassette or material change pulled completely back into the cassette. Using this technique unnecessary material loss is avoided.



## Facts of the RA4 paper processor

Designed for RA4 and compatible processes, our roller transport paper processor is directly connected to the Theta 76 imager. It can be operated as desired with either chemical or flowing wash. The processor contains everything that you expect from a professional device: integrated bath replenishment and bath heating, bath level monitoring and a high performance IR dryer. The processor runs with a transport speed of 52 meters (170 ft.) per hour.



## Can it be anymore comfortable?

If you want to make it even more easy for yourself in handling the Theta 76, then you should decide right away for the external automatic cutter/sorter station. Here, the auto nesting software arranges all images in strips whereby all print sizes are produced on the largest media roll, resulting in maximum flexibility and productivity. And after processing, the cutter&sorter station cuts single images and sorts them to orders. You profit from the simplicity of operation which comes close to a minilab, because you receive ready cut and according to the order sorted pictures.

For even larger sizes there is a larger Y-cutter 50 available, that can cut sizes up to 50 x 70 cm (20 x 30 in.)



DFO - Technology with LED light source and fibre optic

DFO - Print head

Print buffer

Back printer

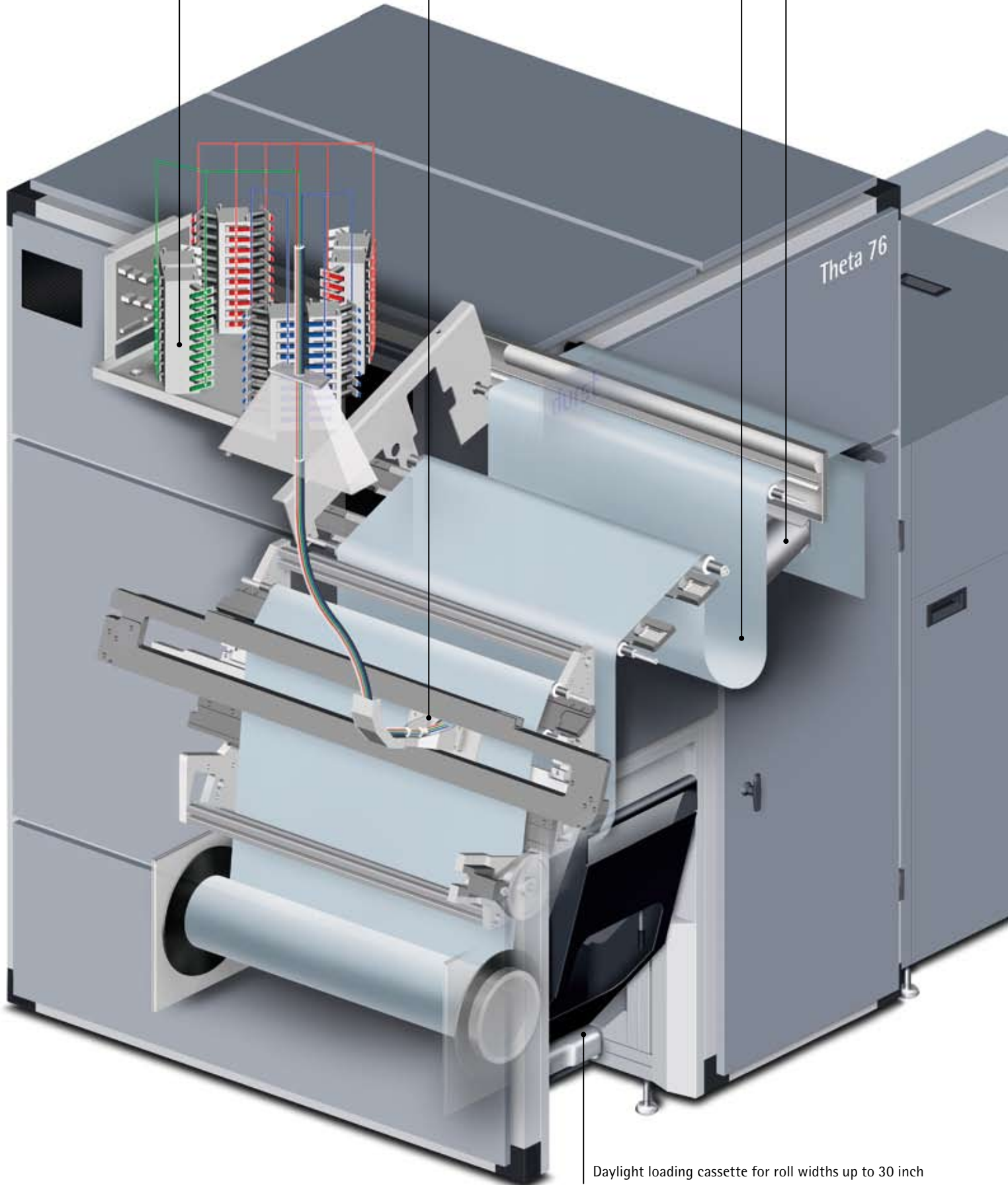

Daylight loading cassette for roll widths up to 30 inch



Infra Red Drier

## The printing unit

At Durst no drums are used as in other systems. Therefore you have the advantage of image sizes up to 4 meter (13 ft.) length – ideal for panorama prints in any length. And this is the procedure: Our patented LED fiber optic light source exposes continuously onto photo paper in rolls. Prints are cut according to the selected print size prior to feeding it into the paper processor. Customer and lab information is printed on the back of the image with the back printer.

## Never again trouble with the latent image

A sensitive subject: The latent image. We have solved the problem without the usual productivity loss and related loss of time as it occurs at other manufactures. And this is how we did it: The exposed material is continuously transported through a "Print Puffer", where the latent image is stabilized prior to the transfer to the processor. This results in a homogeneous image production with a high repeat accuracy. You receive images of highest quality without any color drift.

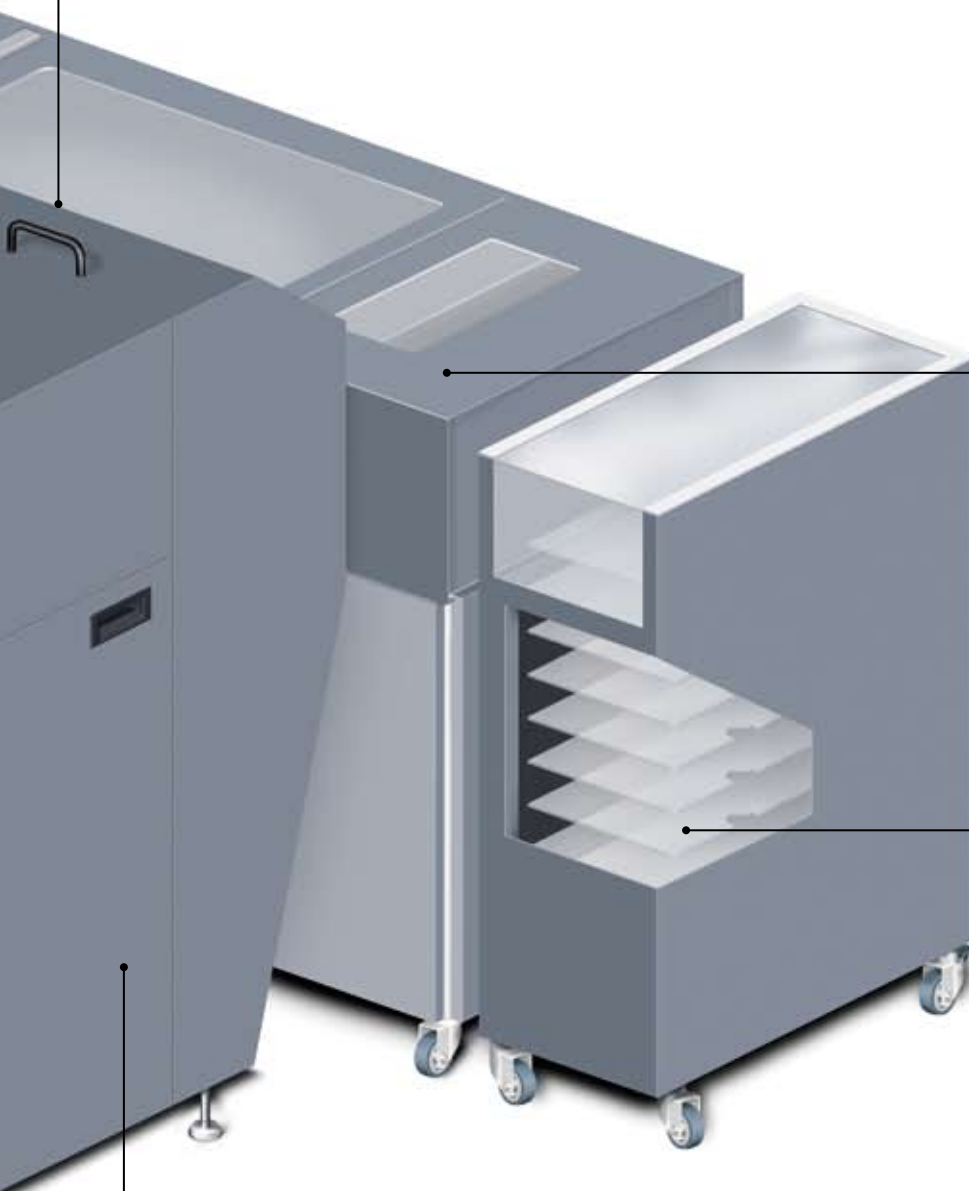

- In-line Y-Cuttter for print sizes up to 30 cm (12 in.) width
- In-line Y-Cuttter for print sizes up to 50 cm (30 in.) width

In-line Y-Cuttter for print sizes up to 30 x 45 cm (12 x 18 in.).

RA4 Paper Processor

# Technical data

## 1.0 General Specifications

### Input voltage:

- 3 Phase + N 230/400V (+/-10 %) 50 Hz; Max Ampere per Phase: 10 A
- 3 Phase 208 V (+/-10 %) 60 Hz; Max Ampere per Phase: 12 A

**Power consumption:**  
6 KVA

**Dimensions:**  
Lengths: 320 cm (126 in.)  
Width: 140 cm (55 in.)  
Height: 188 cm (74 in.)

**Space requirement:**  
250 x 400 cm (158 x 217 in.)

**Weight:**  
approx. 1.500 Kg (3.300 lbs)

**Safety standard:**  
CE

## 2.0 Imaging Specifications

**Printing technology:**  
RGB - LED-Fiberoptic

**Linear output speed:**

- **Theta76**  
variable speed from 40 cm/min. (16 in./min) on maximum roll width up to 72 cm/min (28 in./min) on minimum roll width
- **Theta 76 HS**  
variable speed from 60 cm/min. (24 in./min) on maximum roll width up to 80 cm/min (32 in./min) on minimum roll width

**Resolution:**  
254 PPI

**File formats:**  
Tiff, JPEG, BMP, PPM, PS, PDF

## 3.0 Media Handling

**Media feed system:**  
1 universal, daylight loading media cassettes

**Loading capacity:**  
175 m (530 ft.)

**Suitable media:**  
RA4 Reflective

**Print sizes:**  
(cut sheets from roll media)

- min. 20 x 13 cm (8 x 5 in.)
- max. 76 x 400 cm (30 x 157 in.)
- panels/panorama prints up to 4 m (13 ft.)

## 4.0 Printing capacity

**Printing capacity with max. media width 76 cm (30 in.), printing in Multiple-Print mode or Auto-Nesting mode:**

	Theta 76	Theta 76 HS
9 x 13 cm = (3,5 x 5 in.)	1.528	2.200
10 x 15 cm = (4 x 6 in.)	1.121	1.600
13 x 18 cm = (5 x 7 in.)	778	1.100
20 x 25 cm = (8 x 10 in.)	370	550
30 x 45 cm = (12 x 18 in.)	108	160

**Printing capacity with format matched roll media in print repeat mode:**

	Theta 76	Theta 76 HS
20 x 13 cm = (8 x 5 in.)	332	500
20 x 25 cm = (8 x 10 in.)	198	290
30 x 45 cm = (12 x 18 in.)	84	180
50 x 76 cm = (20 x 30 in.)	47	70
76 x 100 cm = (30 x 40 in.)	24	36

**Printing capacity with file rendering and CMS of unique files in Autospooling mode:**  
reaches approx. 90 % of „print repeat“ capacity

## 5.0 Image Computer

**Workstation:** Pentium IV – 2 GHz (or higher)

**Operating system:**  
Windows XP Professional

**RAM:**  
2 GB

**Monitor:**  
19" LCD color monitor – Resolution 1280 x 1024

**Hard disc:**  
80 GB internal hard disk

## 6.0 Paper processor

**Tank volume:**  
Dev. = 23 L; Bx. = 23 L,  
Wash = 3 x 16 L

**Speed:**  
52 m/h, (170 ft/h)

**Agitation:**  
Via circulation pumps and chemistry filters.

**Wash:**  
Equipped for plumbed and non-plumbed operation

**Replenishment:**  
Automatic, proportional

**Drier:**  
High efficient IR drier

## 7.0 Ambient conditions

**Temperature range:**  
+15 °C to +30 °C (+59 °F to +86 °F)

**Relative humidity:**  
20 - 90 %

The latest technical developments are constantly being incorporated into Durst products. Illustrations and descriptions are therefore subject to modification. All rights reserved on images and illustrations.

© Durst Phototechnik AG, 02/2006  
IX37015



**Durst Phototechnik AG**  
**Social/Portrait Division**  
Vittorio-Veneto-Straße 59  
I-39042 Brixen, Italy  
Telefon +39/0472 81 01 11  
Telefax +39/0472 83 09 80  
www.durst-online.com  
info@durst.it